







DEVICES AND LED NOTIFICATIONS:

CUBE PRO

GUIDE



INTRODUCTION	Pag. 3
 BATTERY CHECK	Pag. 5
 TURN ON	Pag. 6
 CONNECTION	Pag. 7
 SCAN	Pag. 8
 COMPASS	Pag. 9
 FIRMWARE	Pag. 12
 ERROR WARNINGS	Pag. 13



TIP



ADVICE

INTRODUCTION

Welcome to the guide for your **CUBE_{PRO}**.
For its use, it is first necessary to download
The Meter app; you can find it at **Google Play**
or **Apple Store**, or by scanning the **QR code**
here on the right

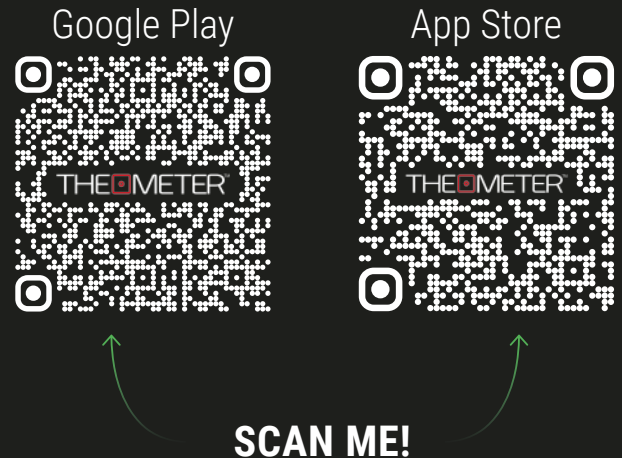

THE METER **CUBE_{PRO}** is an automatic space measuring device designed to eliminate human error. It will allow you to survey spaces with maximum precision and to export a Digital floor plan in less than a minute. Lightweight and compact, it combines the technologies of laser rangefinders and digital protractors in a unique product with the latest IOT technology

What is your **CUBE_{PRO}** made up of? Here below the hardware component list

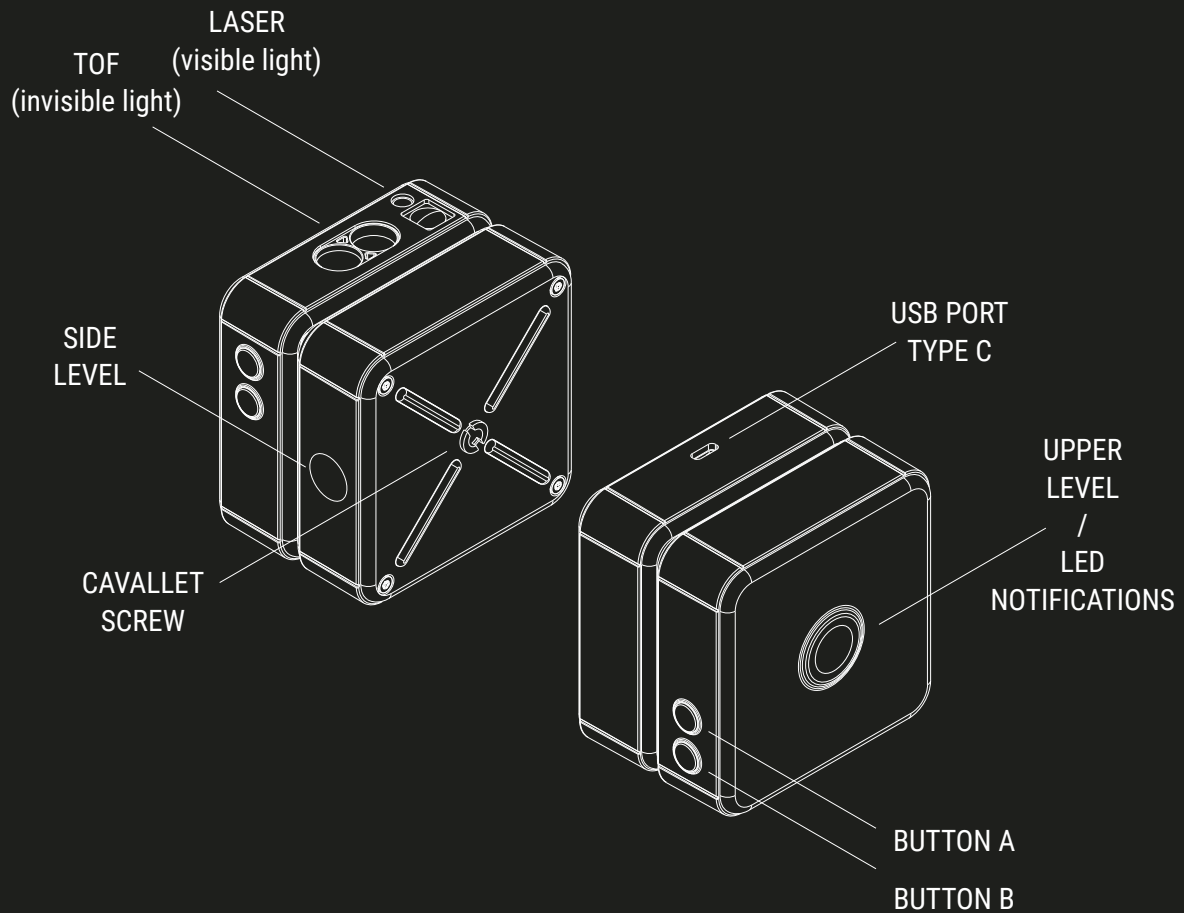

BATTERY CHECK 

By clicking the button A  when the device is turned off you can check the charging status of your **CUBE_{PRO}** by green blinking of the upper level:

1 blink \geq 25%, 2 blinks \geq 50%, 3 blinks \geq 75%, 4 blinks 100%

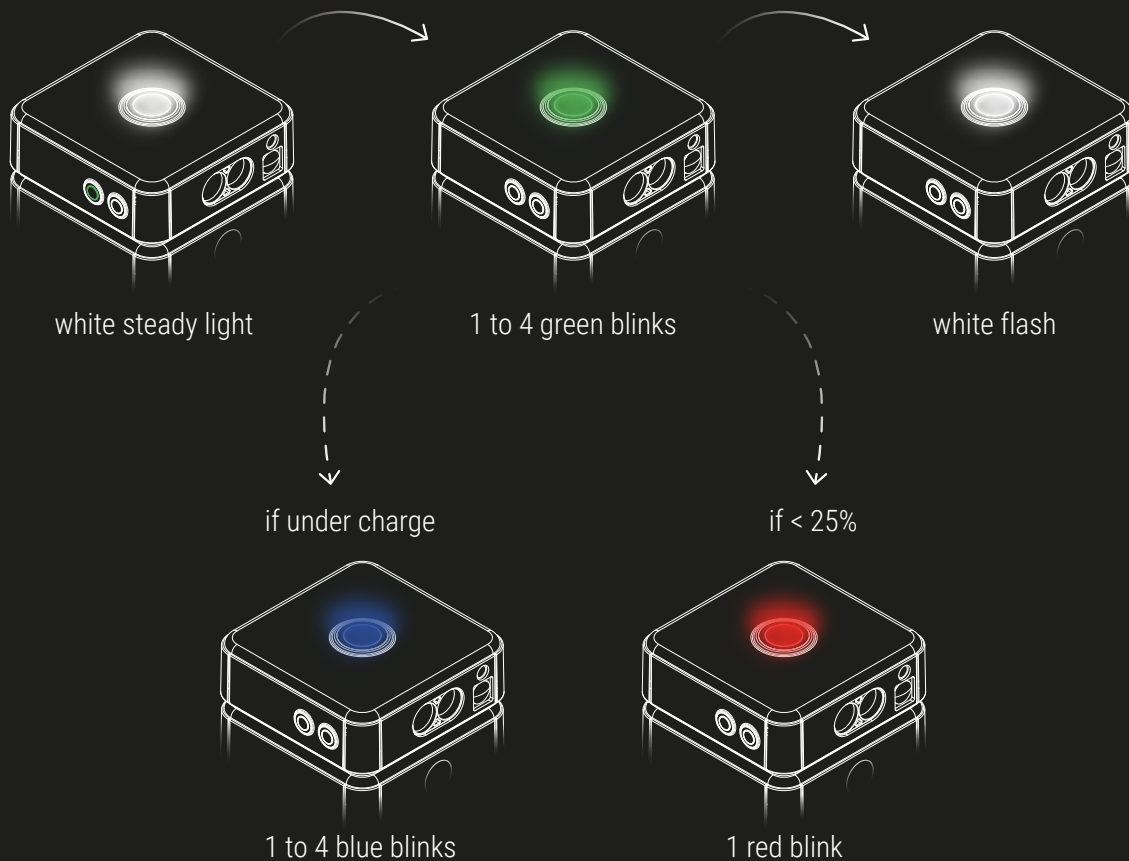

When the device is charging, the blinks are blue.
If the battery is less than 25%, the LED blinks red

TURN ON ○

To turn on the device hold down the button A ○ until the led light turns green.
Similarly, for shutdown, hold down button A ○ until the light turns white.



CUBE_{PRO} turned off:
start pressing the button A

Steady white light:
continues to press the button A

Blinking green light:
turn on completed

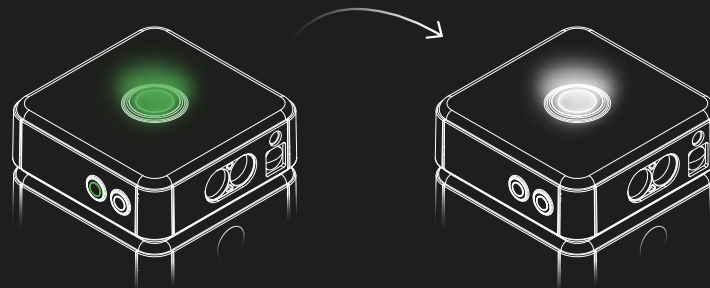

CUBE_{PRO} turned on:
start pressing the button A

Blinking green light:
shutdown completed



To perform a device reset, hold down both buttons
until the LED remains off for at least 10 seconds

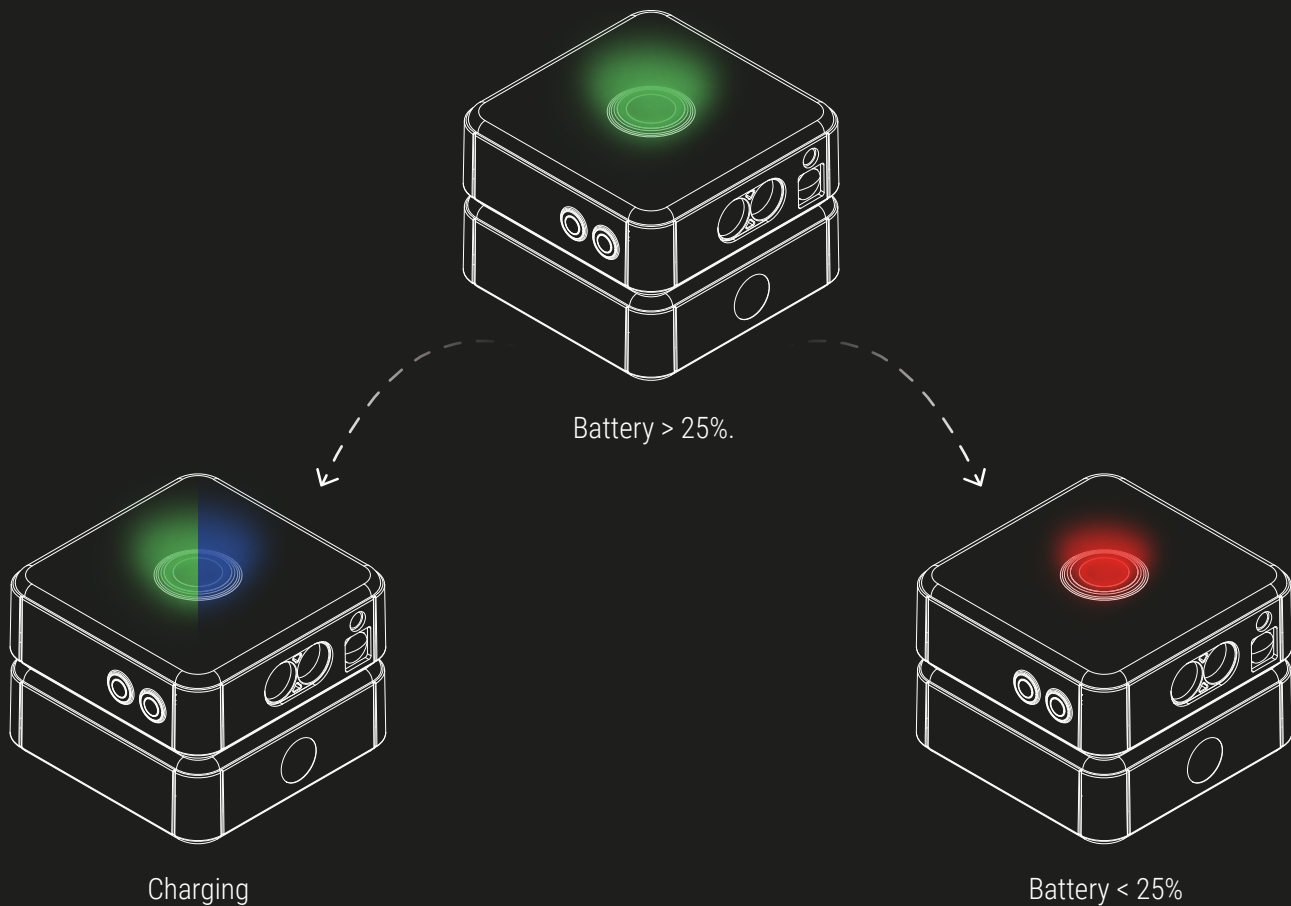

Once the **CUBE_{PRO}** is turned on, the LED blinks green, signaling the wait to connect to a mobile device. Once connected the light turns steady green

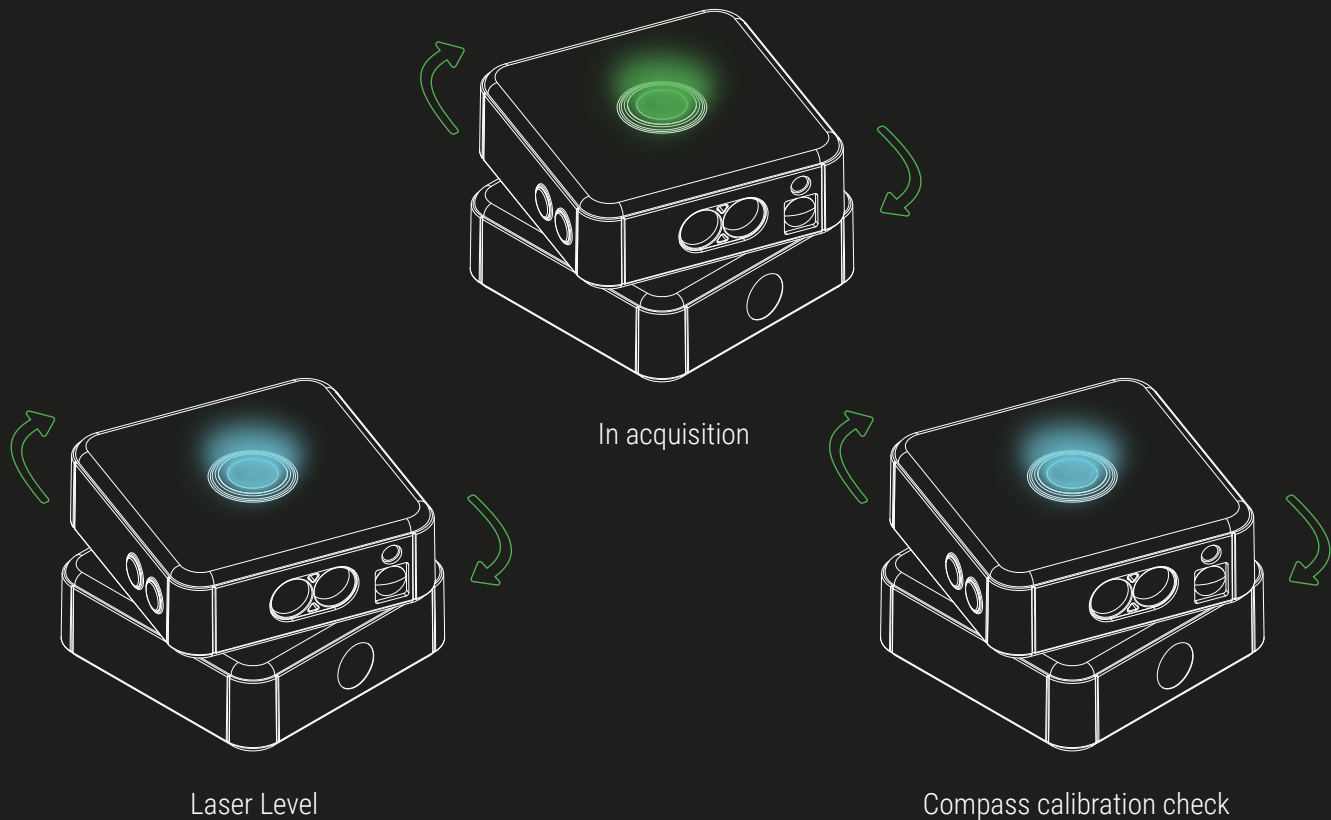

If the **CUBE_{PRO}** is charging, the LED alternates blue blinks to green ones;
if the battery is less than 25% the LED signals are colored red

During acquisition operations, the LED has a steady green light



In control operations, the LED has steady blue light during execution of the laser level , while it has blue flashing light during the compass calibration test 

To perform compass calibration, place the **CUBE_{PRO}** on a horizontal flat surface;
now you can start the Calibration  function from the Fast Pad 
menu of the Automatic  mode in The Meter App

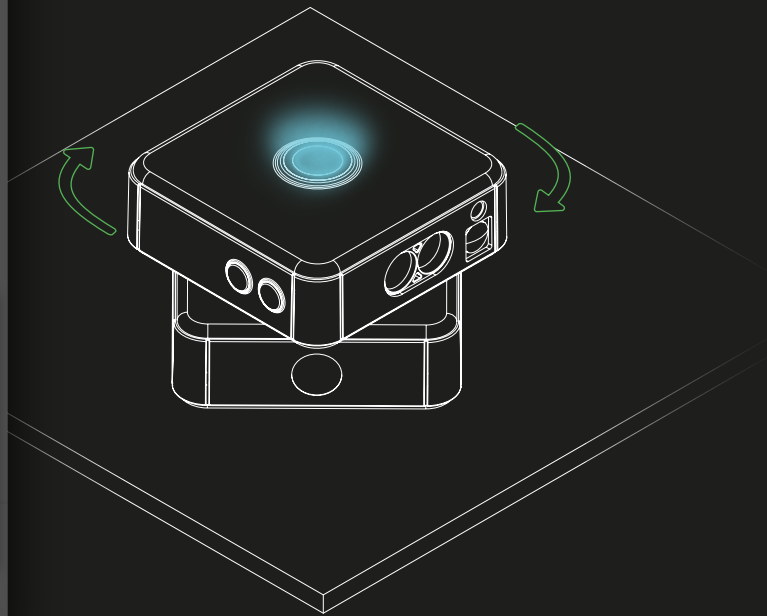
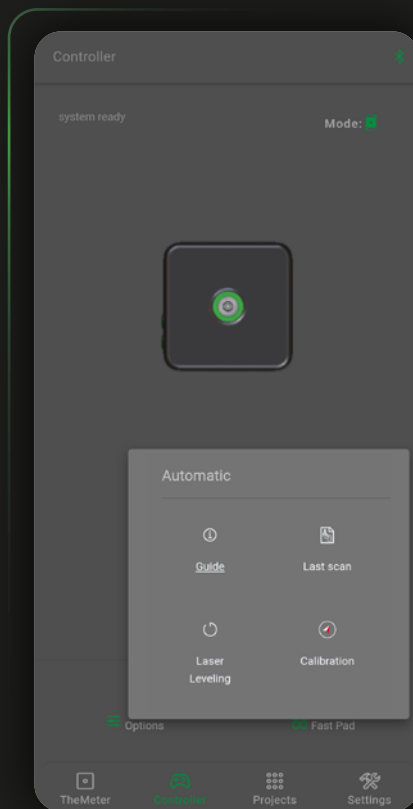

The device will start a test to check the current calibration of the compass by turning the head 360° in 4 steps; During the procedure the led signal is light blue, steady in motion and flashing between steps

Once the test is completed, if it's needed, you can continue with the calibration of the device compass; alternatively, you can decide to click **CANCEL** and continue working with your **CUBE_{PRO}**, but having the North indication in the results incorrectly

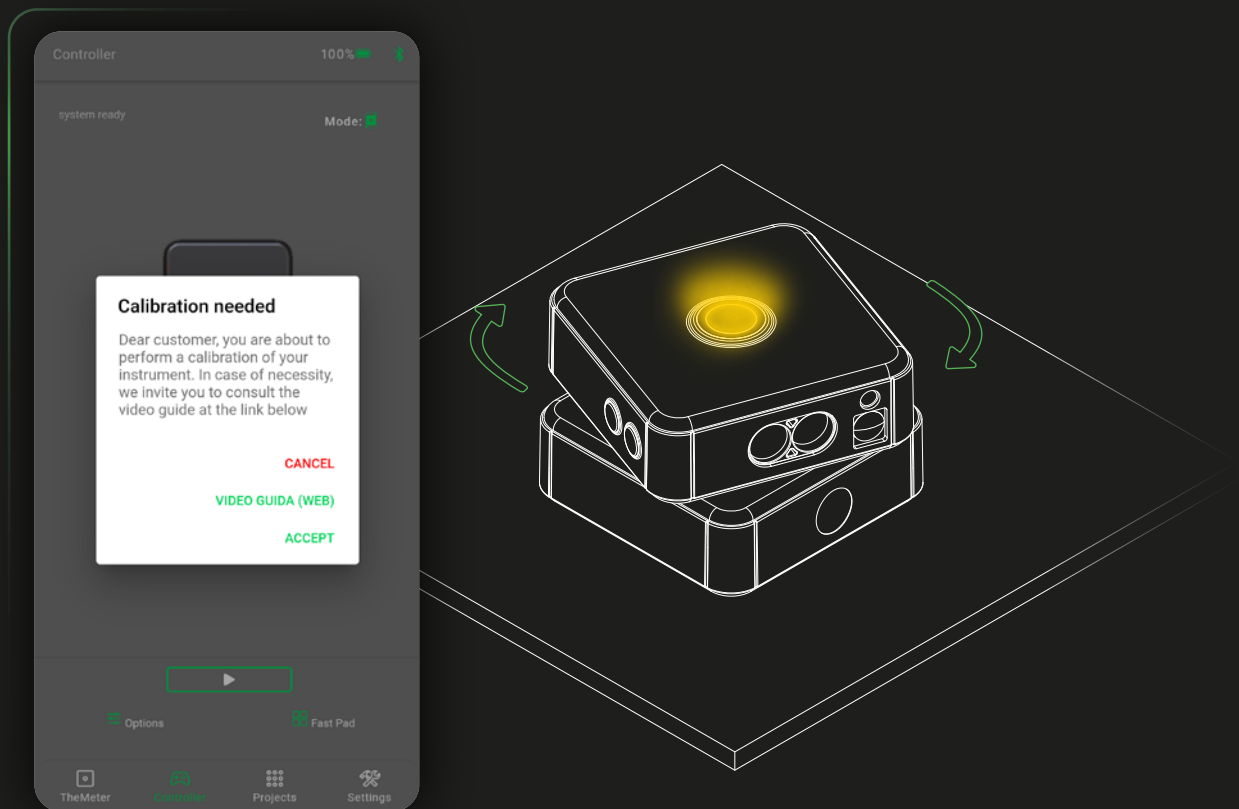

Clicking **ACCEPT** a calibration session starts: when the upper level starts flashing yellow, rotate the head of **CUBE_{PRO}** on itself until the light turns flashing light blue.

Turn now the **CUBE_{PRO}** on its side, with side level and buttons upwards; rotate the device on itself until the light turns green

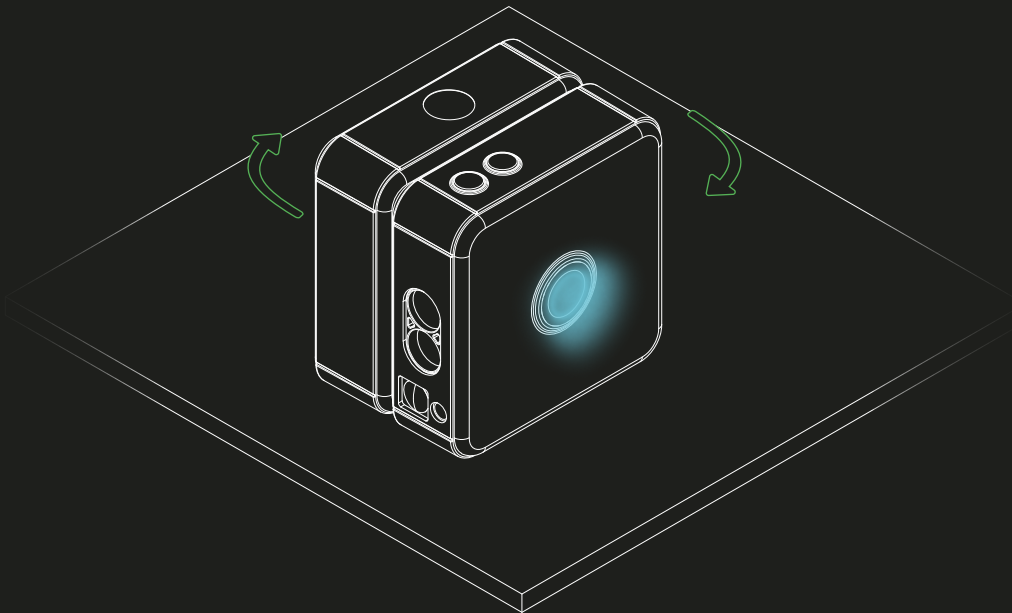

To optimize the calibration of your **CUBE_{PRO}** perform the rotations at a rhythm of one every 7 to 8 seconds circa without ever stopping the movement

During the Firmware update, to be executed only through the TheMeter Doctor app, the led performs a sequence of light signals to inform us at what stage of the process we are: initially, in the download phase, it has steady purple light

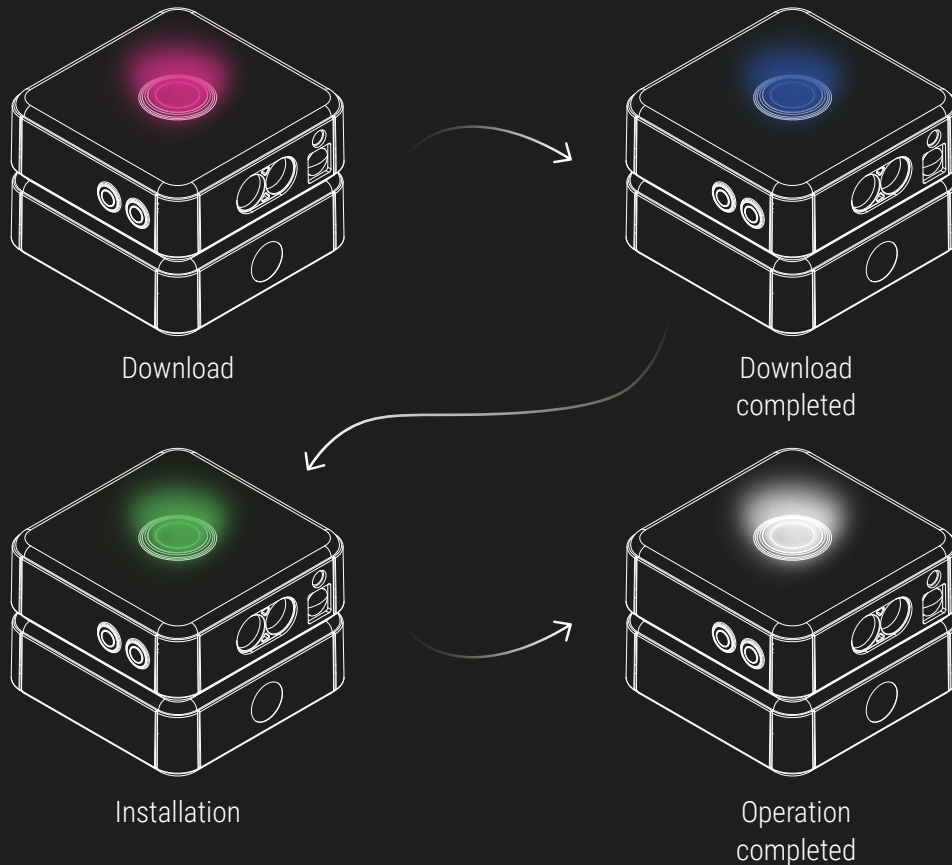

When the download is finished, the LED is blue, and changes to green when the installing process begins; the end of the process is notified by the LED changing to white and the automatic disconnection of **CUBE_{PRO}** from the device

ERROR WARNINGS 

If during the firmware update the led signal remains steady purple for more than 2 minutes, it means that an error has occurred within the update process; To fix it make sure the device is connected to The Meter Doctor app and restart the procedure; if the problem persists contact THEMETER support.

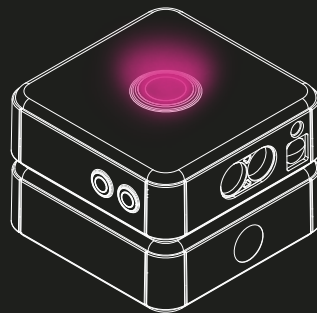

Initialization error
Firmware



Upgrade via
The Meter Doctor app

Contact THEMETER support

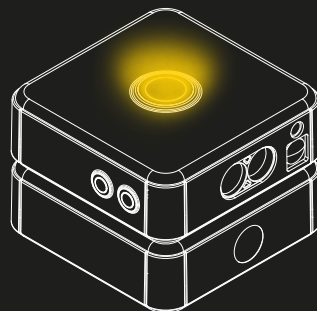

Initialization error
hardware component



Button A
Power On/Off



Button A + Button B
Reset

Contact THEMETER support

If during the turn on of your **CUBE_{PRO}** the LED returns steady yellow light, it means that an initialization error occurred in one of the internal peripherals; As a solution try to turn the device off and on again, and if the signal does not change perform a reset; if the problem persists, contact THEMETER support.

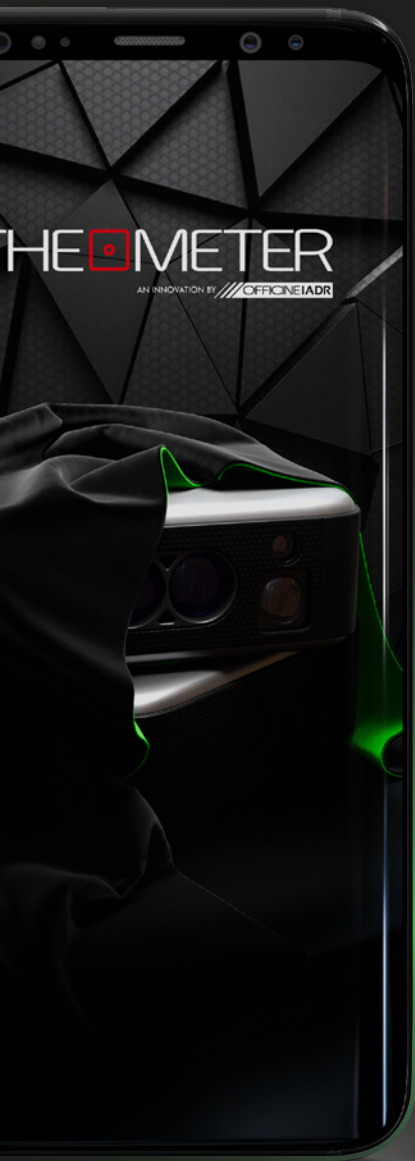

Images used are for illustration purposes only, may differ from reality
Some features are not available in all regions.

© 2021 Officine IADR SRL

All rights reserved. Designed by Officine IADR printed in Italy